

AC/DC sensitive residual current monitoring module RCMB121-...

for safe charging of electrical vehicles according to IEC 62752 for IC-CPD and IEC 60364-7-722 for Wall Boxes



AC/DC sensitive residual current monitoring module RCMB121-...

for safe charging of electrical vehicles according to IEC 62752 for IC-CPD and IEC 60364-7-722 for Wall Boxes



RCMB121-2

Features

- IEC 627582 and UL 2231 version available
- Frequency range DC to 2 kHz
- Full load current up to 80 A rms (1-phase) or 3 x 32 A rms (3-phase)
- Switching output for 6 mA DC/30 mA rms (IEC) or 5 mA rms/20 mA rms (UL2231)
- Error output (Integrated self-monitoring and test functions)
- Measurement resolution 0.2 mA
- Variants with feed through opening or with integrated primary conductors
- Residual current range 0...300 mA
- Robust mechanical design suitable for IC-CPD environmental requirements (e. g. drop test)
- Widely usable in harsh electronic environments (e.g. resistant to external fields)
- Total system cost significantly reduced compared to RCD type B

Different Types

Planned variants of the VAC/Bender DI Sensors:

- Version with primary feed through opening for full flexibility
- Version with integrated primary conductors for 1-phase systems
- Version with integrated primary conductors for 3-phase systems
 - Standard versions are designed for PCB mounting and wave soldering process.
 - Customer specific design (e.g. press fit) upon request.

VAC/Bender DI sensors are optimized for fast, low-cost assembly, combined with the highest product and production quality.

Applications and Advantages

To satisfy new standards including IEC 62752 and IEC 60364-7-722, the charging of electrical vehicles requires residual current sensors to avoid hazardous situations in cases where the vehicle battery (DC) is connected to the home power supply (AC). Generally, AC/DC-sensitive residual current sensors can be used where direct current and alternating current circuits are directly connected and therefore AC/DC leakage currents can occur.

Typically type A residual current circuit breakers (RCCBs) are installed in private households. However, these RCCBs are to identify and deactivate DC fault currents. In order to charge an electric vehicle (EV) from a home power supply, a costly type B RCCB would be required to guarantee safety in the event of a DC fault current.

By using a VAC/Bender DI sensor integrated into an IC-CPD or wall box, customers can save the high costs of installing a type B RCCB to provide all-current sensitivity and electrical safety at low cost.

A single DI sensor simultaneously monitors all currents in phases and neutral conductors sensing AC/DC fault currents. The sensors can activate automatic shut-off in the event of hazardous electrical faults. As the residual currents to be monitored only occur in the event of electrical faults and are extremely low (mA), maximum measurement precision is critical. In addition, a fast response time is required to maintain safety features.

i *Manufactured with soft tools (plastic components) and production tools and facilities that are not definitive.*

i *Status before design freeze, subject to modifications regarding technical characteristics and external dimensions until subsequent series production.*

Standards

Constructed and manufactured and tested in accordance with IEC 61800-5-1, IEC 62752 (In-Cable Control and Protection Device for mode 2 charging of electric road vehicles (IC-CPD)) and IEC 60364-7-722 (Low-voltage electrical installations - Part 7-722: Requirements for special installations or locations - Supplies for electric vehicles).

Ordering Information

Version	Type Bender	Art. No.
IEC	RCMB121-1	B 9404 2490
UL	RCMB121-2	B 9404 2491

Schematic output diagram:

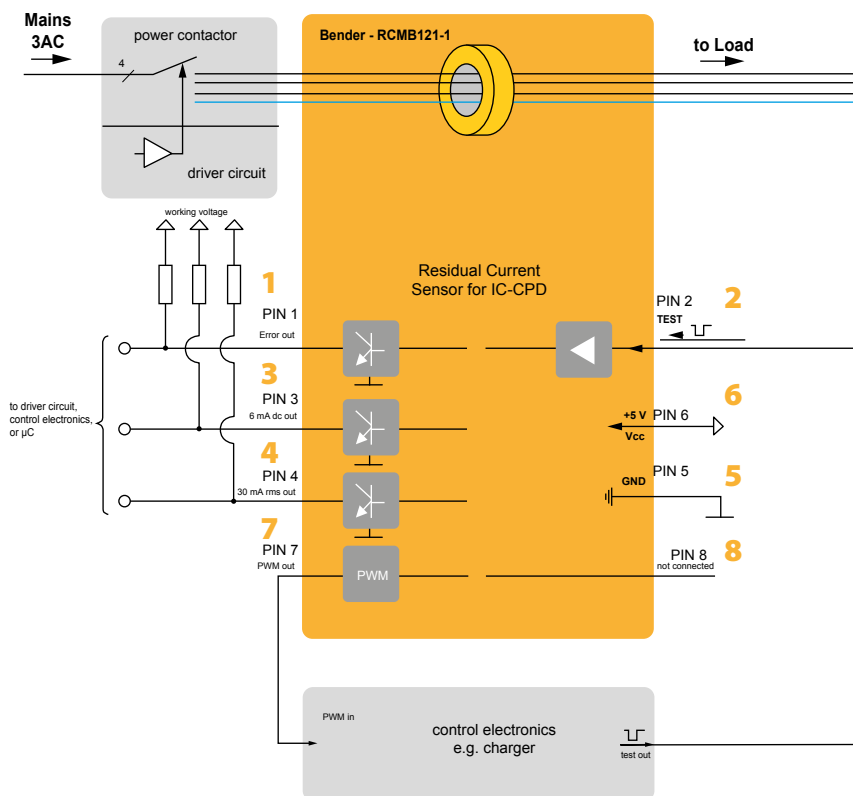

- 1 - Pin 1 – ERROR OUT**
If no system fault is detected, Pin 1 outputs a low level. If a system fault is detected Pin 1 has high impedance. (active low)
- 2 - Pin 2 – Test IN**
Input is active if a low pulse (GND) is applied for a period of 30 ms to 1.2 sec. Input is inactive if left open.
- 3 - Pin 3 – 6 mA dc OUT**
If the residual current is below 6 mA dc and no system fault occurs, Pin 3 outputs a low level. In all other cases Pin 3 has high impedance. (active low)
- 4 - Pin 4 – 30 mA rms OUT**
If the residual current is below 30 mA rms and no system fault occurs, Pin 4 outputs a low level. In all other cases Pin 4 has high impedance. (active low)
- 5 - Pin 5 – GND**
- 6 - Pin 6 – +VCC**
- 7 - Pin 7 – PWM OUT**
Depending on the fault current, a PWM with $f = 8 \text{ kHz}$ is generated.
Scaling:
IEC: $0 \dots 100 \% = 0 \dots 30 \text{ mA dc}$ or
UL: $0 \dots 100 \% = 0 \dots 50 \text{ mA rms}$
- 8 - Pin 8 – not connected**

Technical Data

Electrical data - Ratings

I_p	Primary nominal RMS current (1 phase/3 phase)	80/40 A
$I_{\Delta N1}$	Differential rated fault current 1 (DC/RMS) (IEC/UL)	6/5 mA
$I_{\Delta N2}$	Differential rated fault current 2 (RMS/RMS) (IEC/UL)	30/20 mA
$I_{\Delta N1tol}$	Fault current 1 tolerance	-30...0 %
$I_{\Delta N2tol}$	Fault current 2 tolerance (DC to 1 kHz)	-20...0 %
$I_{\Delta N2tol}$	Fault current 2 tolerance (1 kHz to 2 kHz)	-20...+50 %

Accuracy – Dynamic performance data

$I_{\Delta N,max}$	Max. measuring range (peak)	-300...+300 mA
X	Resolution (@ $I_{\Delta N}$, $\vartheta_A = 25^\circ\text{C}$)	< 0.2 mA
t_r	Response time	According to IEC 62752 5.3.11 (rev. Sept 2012)
f_{BW}	Frequency bandwidth	DC 2 kHz

General data

ϑ_A	Ambient operation temperature	-40...+85 °C
ϑ_S	Ambient storage temperature	-40...+85 °C
m	Mass	23 g
V_{CC}	Supply voltage	4.8...5.2 V
S_{clear}	Clearance (component without solder pad)	not applicable if insulated cable is used
S_{creep}	Creepage (component without solder pad)	not applicable if insulated cable is used

Electrical data of Open Collector Outputs:

Collector–Emitter voltage	40 V
Collector Current	50 mA

Electrical data (determined by type checking)

$V_{CC,max}$	Maximum supply voltage (without function)	7 V
U_{VMAX}	Maximum rated voltage (of primary conductor)	300 V
$\Delta X_{Ti/\Delta T}$	Temperature drift of resolution (@ $\vartheta_A = -40 \dots +85^\circ\text{C}$)	tbd ppm/K
Mechanical stress according to M3209/3 (DIN 60068-2-6: 2010)		
Settings: 10...2000 Hz, 1min/Octave, 2 hours		tbd g

Dimension diagram

Dimensions in mm

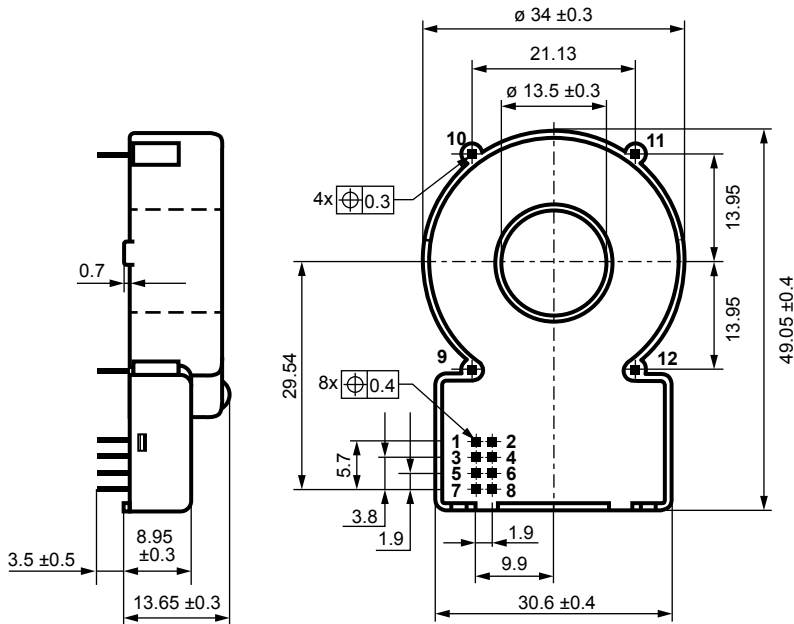

Meaning of switching recovery level

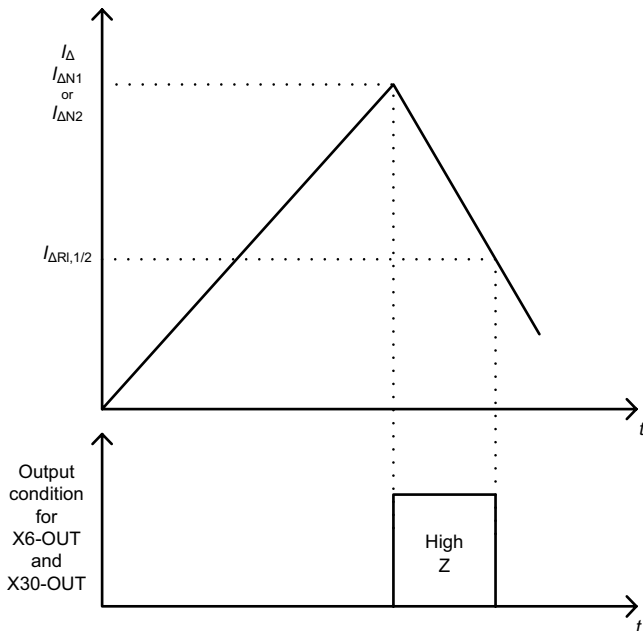

If the trip-level $I_{\Delta N1}/I_{\Delta N2}$ is accomplished the output X6-OUT/X30-OUT will change its state from low-level (GND) to high impedance.

Depending on the existence of the differential current I_{Δ} , the outputs X6-OUT/X30-OUT will remain in this state until I_{Δ} fell below threshold $I_{\Delta RI1}/I_{\Delta RI2}$.

TEST-IN Timing Diagram

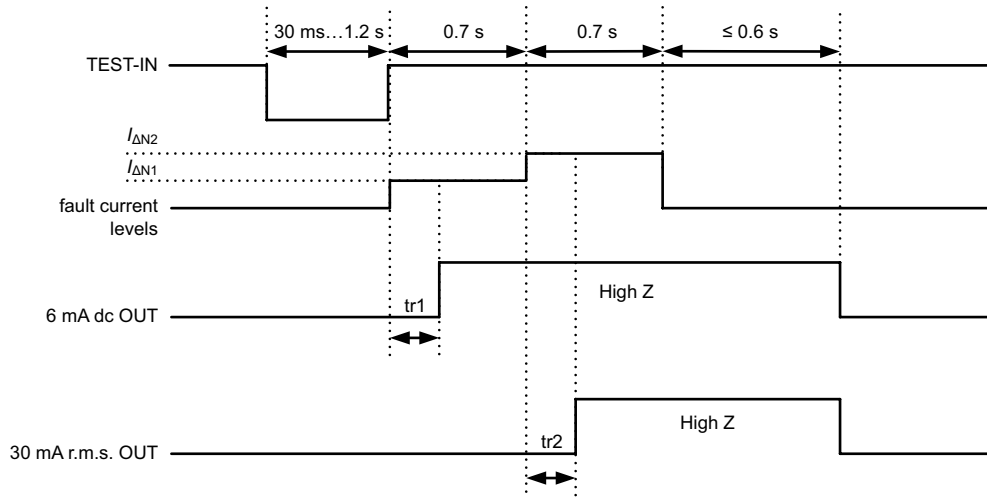

Interrupting Time according to IEC62572:2012

Trip level and timing according to IEC 62572:2012 Tab. 2a + 2b

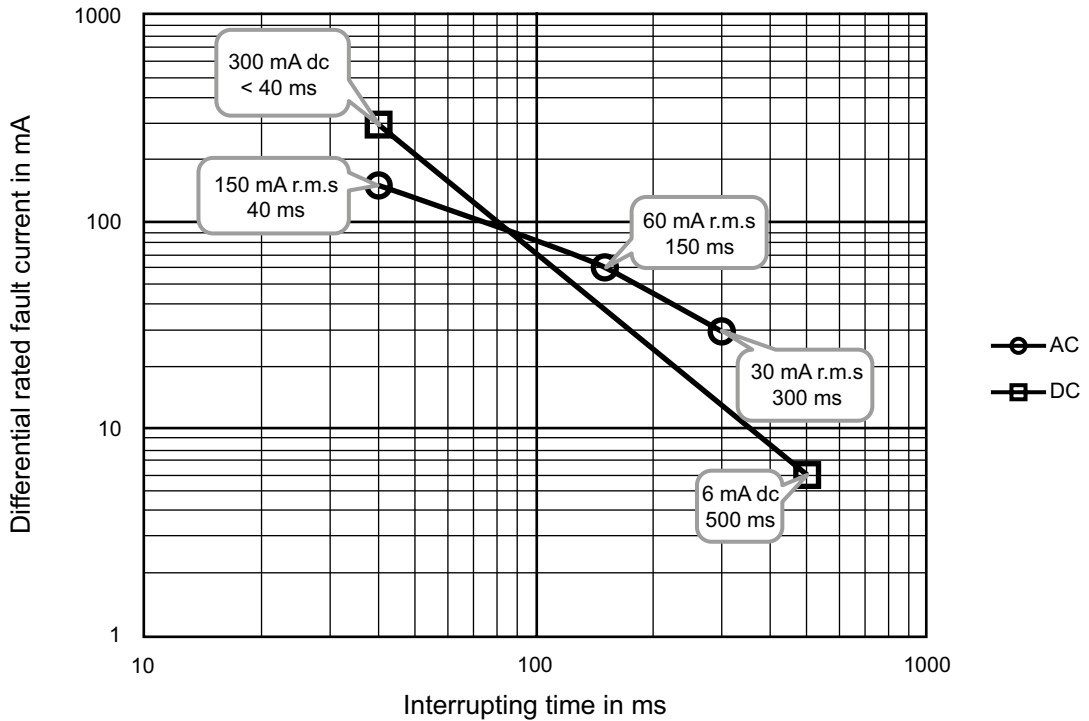



Bender GmbH & Co. KG

Postfach 1161 • 35301 Grünberg • Germany
Londorfer Straße 65 • 35305 Grünberg • Germany
Tel.: +49 6401 807-0 • Fax: +49 6401 807-259
E-Mail: info@bender.de • www.bender.de